



# Geo Semiconductor Inc.

## Niobe Evaluation Board for Realta -- Video Processing IC



The Geo Semiconductor Niobe Evaluation Board is a high performance reference platform for the Realta image processor. The purpose of this platform is to allow system developers and software engineers to evaluate the image quality of the Realta HQV™ solution and to develop, test, and prototype the final display application. All the key electronics, including the Realta image processor, are contained on a single PCB.

The board input section supports the following interfaces: DVI-I, Analog RGB, Component SD, Component HD, Composite NTSC/PAL, and Composite S-Video NTSC/PAL. The reference platform provides three different decoding paths for the input video signals, through the ADV7402 (multi-format SDTV/HDTV video decoder and RGB graphic decoder), the Si1161B (DVI receiver), and the SAA7119E (multi-standard video decoder).

The reference platform provides two video output formats (DVI and RGB) on the DVI-I connector. The digital output is generated by the Si1164 DVI transmitter, and the analog output is generated by the ADV7123 DAC.

Bundled with the Niobe platform are the Realta Evaluation Kit (containing Basic Hardware Kit, Firmware, DTK, and Documentation) and the Realta Development Kit (containing Basic and Additional Hardware Kits, Firmware, DTK, ODK, SDK, and Documentation). The software components include configuration and debug tools (to simplify verification and debugging), user friendly file management software (for code uploading/downloading and general file management), and powerful On Screen Display (OSD) design tools (for OSD custom-tailoring). The Documentation CD includes board design files and supporting documentation, to aid in the rapid development of system applications..

---

### **World Headquarters**

#### **Geo Semiconductor Inc.**

2350 Mission College Blvd., Ste.1050,  
Santa Clara, CA – 95054 USA

### **Development and Operations Center**

#### **Geo Semiconductor Inc.**

155 Gordon Baker Road, Suite 201  
Toronto, Ontario, M2H 3N5 Canada

**Website :** [http:// www.geosemi.com](http://www.geosemi.com)



# Geo Semiconductor Inc.

## Block Diagram

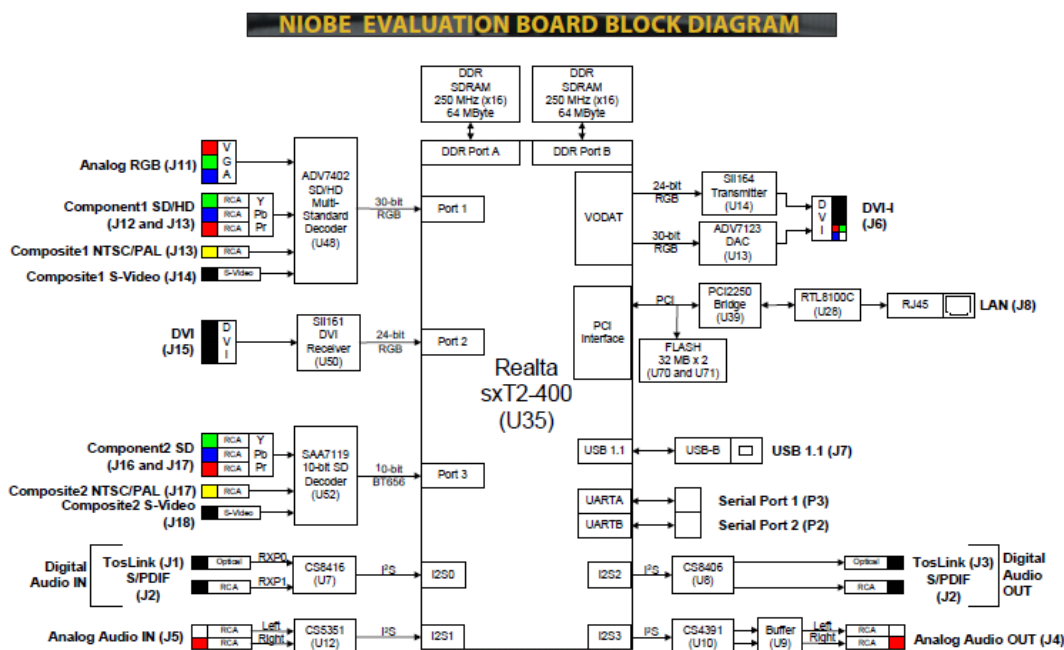

## KIT CONTENTS

### Basic Hardware Kit

- Niobe Evaluation Board
- 12 V power supply with cable (110/220 V)
- Serial UART cable (DB9 to 3-pin RS-232 adapter cable for serial data I/O)
- RS-232 extension cable
- Category 5 Ethernet cable
- DVI-I output adapter connector (DVI-I to RGB)
- Keypad with cable
- IR remote control

### Additional Hardware Kit

- Chameleon JTAG controller
- JTAG adaptor cable (14-pin to DB25)
- Extension parallel port cable for the Chameleon (JTAG controller)

The board comes included with standard firmware needed to achieve the video processing functions. The developers tool kit (DTK), OSD Development tool kit (ODK), Software development kit (SDK) and documentation CD are available separately.

### World Headquarters

#### Geo Semiconductor Inc.

2350 Mission College Blvd., Ste.1050,  
Santa Clara, CA – 95054 USA

### Development and Operations Center

#### Geo Semiconductor Inc.

155 Gordon Baker Road, Suite 201  
Toronto, Ontario, M2H 3N5 Canada

Website : [http:// www.geosemi.com](http://www.geosemi.com)